

PondMAX

WATERGARDENING TO THE MAX

FILTRATION & WATERFALL PUMP

INSTRUCTION MANUAL



evolution
SERIES

888.868.1185

info@pondmax.com

www.pondmax.com

VERSION
AUG 2022

MODEL
EP700
EP1100
EP1700
EP2300
EP2900
EP3500

WELCOME TO THE WORLD OF **PONDMAX™**.
 YOU MADE THE RIGHT CHOICE INVESTING IN THIS
 QUALITY PRODUCT. **THANK YOU AND ENJOY.**

TECHNICAL SPECIFICATIONS

DESCRIPTION	EP700	EP1100	EP1700	EP2300	EP2900	EP3500
MAXIMUM WATER FLOW(GPH)	850	1250	1850	2400	3000	3450
MAXIMUM HEAD (FT)	10	13	16	18	21	23
POWER CONSUMPTION* (W)	20W	40W	70W	100W	140W	170W
VOLTS (V)	115	115	115	115	115	115
FREQUENCY (Hz) AC	60	60	60	60	60	60
CABLE LENGTH (FT)	32	32	32	32	32	32
INLET Ø MALE PIPE THREAD (INCH)	1	1	1	1.5	1.5	1.5
OUTLET Ø MALE PIPE THREAD (INCH)	1	1	1	1.5	1.5	1.5
STEPPED HOSETAIL SIZE (INCH)	1/1.25/1.5	1/1.25/1.5	1/1.25/1.5	1/1.25/1.5	1/1.25/1.5	1.5/2
RECOMMENDED TUBING SIZE (INCH) ID	1	1.25	1.25	1.5	1.5	2
PRODUCT ORDER CODE	22PU041	22PU042	22PU043	22PU044	22PU045	22PU046

* SUBJECT TO VARIATION ACCORDING TO LOAD.

DESIGN HIGHLIGHTS

The PondMAX Filtration & Waterfall Pumps have been manufactured with advanced technology to provide you with the best quality pumps for your pond or water feature. Visit our website to view our range of pond filtration, outdoor/ underwater lighting, water treatments and general accessories.

- **SMART MAG™ Motor Protection** - Provides longevity by preventing motor burnout.
- **Energy Efficient** - Exceptionally low power consumption.
- **Optional Adjustable Auxiliary Inlet** - Allows for connection to optional accessories such as a skimmer or secondary suction point within pond or water feature.
- **Eco Friendly** - Very low noise rating with minimal mechanical vibration.
- **Open Vane Impeller Design** - Resists clogging and can handle debris up to 3/8" in diameter.
- **Can Be Installed Vertical or Horizontal** - Provides flexibility for installation in many different applications.
- **Tool-less Assembly** - Easy maintenance. No special tools required.

FILTRATION & WATERFALL PUMPS

BENEFITS

- PondMax™ Filtration & Waterfall Pumps offer an integrated Auxiliary Inlet function, to enhance filtration systems, by allowing for additional water circulation/waste collection.
- Your pump has a single moving part (an impeller) enabling easy cleaning and maintenance.
- All of the Filtration & Waterfall Pumps have SMARTMAG™ motor protection. SMARTMAG™ provides a soft start for the pump on startup and helps to avoid any sudden movement. Also if the Impeller gets jammed or stops, the pump will sense the situation and cut the power automatically for 3 seconds and then power up again. This procedure will repeat 3 times. If the rotor is still jammed, it will activate a prolonged low state, till the pump is turned off, and appropriate maintenance is carried out. Thus minimizing motor burnout, due to electrical heat, through lack of water flow through the motor.
- The motor and electrical components are totally encapsulated in epoxy resin, ensuring safe operation in the water.
- The pump has a robust bearing and shaft design that relies on water to cool and lubricate it, so no oil or grease lubrication is required.
- PondMAX Filtration & Waterfall Pumps are rated for continuous-duty, therefore are designed to operate 24/7.



IMPORTANT SAFEGUARDS

Please read the operating instructions and familiarize yourself with the equipment before placing it in service. Correct and safe use of the system requires strict compliance with the safety instructions.

For safety reasons persons less than 16 years of age or people that are not familiar with these instructions should not use this equipment.

- Any damage to the equipment or unmerited operation will bring dangers to the surrounding precincts. So if there is any damage of the equipment, it must not to be used. The equipment should be placed out of reach of children.
- For your own safety, disconnect from the power supply before any maintenance. Always unplug the pump from the power supply when not in use.
- Never pull the cable to disconnect the plug from the power supply - Grasp the plug and pull to disconnect. If required, have a qualified electrician install a weatherproof power supply point near to the pond or water-feature (within the cable length of the appliance).
- Make sure the equipment is completely covered in water before operating. The depth should not be greater than 6.5ft.
- Do not operate the pump if the appliance or any components of the system, such as the power cable, have been damaged. Check appliance for defects regularly.
- For safety, plug the pump into an electrical outlet with a (GCFI) Ground Fault Circuit Interrupter.
- To avoid an electric shock, do not attach the plug to the power supply socket with wet hands. On installation, the drip loop method should be used to prevent water from traveling down the cable and onto the plug or power supply. If the plug does get wet, do not unplug the cable. Immediately disconnect the circuit breaker that supplies power to the power supply point. Then unplug and examine the plug, and power supply point, for presence of water. If the power point has become wet, you should consult an electrician before using the power point again.
- Do not cut the cable as this will result in voiding your warranty.
- Do not install or store the appliance where it will be exposed to extreme hot or cold temperatures. Do not use in water above 95°F.
- Care should be taken to arrange the power cable so that it cannot be accidentally tripped over or pulled.
- Do not attempt to repair the electrical appliance yourself. Return to an authorized service center or place of purchase if a fault occurs, (regular maintenance is not considered repair and is required by user).

PRODUCT SPECIFIC SAFEGUARDS

- Do not operate the pump without water at any time, permanent damage may occur.
- Make sure the pump is completely submersed in water before operating. The depth should not be greater than 6.5Ft.
- The pump is designed to be used for fresh water applications. The pump should only be used in clean water. Do not use the pump in, or with, any chemicals such as a solvent or gasoline.
- PondMAX Filtration & Waterfall Pumps are cooled by water flowing through the inside of the motor body. If the pump flow becomes restricted it will overheat and could cause permanent damage. Large tubing size is strongly recommended to deliver adequate water flow to cool the pump.
- The pump needs to be cleaned regularly to prevent the pump becoming blocked, thus causing the pump to overheat and burn out. This is not a warrantable event. It is strongly recommended not to select a pump that is too small for the job required. The flow rate through the pump needs to be enough so that a half of the rated max flow is kept running at all times.

INSTALLATION

When used inside a pond or water feature environment, without using auxiliary inlet function- follow procedure as outlined below:

- First make sure that a weatherproof power point is accessible near to the pond or water feature (within the cable length of the pump), to provide power to operate the pump.
- Next determine tubing size for your specific pump model (see "technical specifications" table in this manual). Once you have determined the tubing size, go ahead and choose which type of fittings best suit your application, from the different options provided.

NOTE: IF YOU CHOOSE TO USE THE HOSETAIL FITTINGS, MAKE SURE TO TEST THE TUBING ON BARBS TO DETERMINE WHICH OF THE BARB STEPS WILL BE USED. MAKE SURE TO REMOVE ANY OF THE STEPPED BARBS THAT ARE SMALLER (IF APPLICABLE) THAN THE BARB YOU ARE GOING TO UTILIZE, OTHERWISE IT CAN RESULT IN UNNECESSARY RESTRICTION TO THE PUMP.

- Before connecting the tubing, connect the appropriate adapter to the pump outlet, making sure to use the flat rubber gaskets and locking nut provided (ref. "Exploded view" later in this manual). Slide the gasket into the locking nut and thread the locking nut in firmly. The correct use of the gaskets is important and can eliminate the use of thread seal tape. A pivoting ball joint is also provided for your convenience and can reduce tubing kinks, but is totally optional. Use pivoting ball joint only when pump is installed underwater.
- Now connect the tubing to the adapter installed on outlet of the pump and fasten firmly with hose clamps or glue (not included), depending on the fittings being used.
- Place the pump in desired location in the pond or water feature. Ensure the pump is on a stable surface that is free of sludge, sand and other debris. Do not place the pump upside down.
- Direct the remaining end of tubing to either your filtration system or to the top of your waterfall.
- Ensure pump is fully submersed and double check that all plumbing connections are secure, then plug in pump power cord to test operation of pump.

WHEN USED WITH AUXILIARY INLET FUNCTION- FOLLOW INSTRUCTIONS ABOVE AND BEFORE YOU INSTALL PUMP, PROCEED AS OUTLINED BELOW:

- Construct the auxiliary inlet fittings together per the "exploded view" diagram shown later in this manual. Make sure to use the O-rings provided on the locking nuts and secure fittings firmly together, making sure to not over-tighten.
- Before connecting the auxiliary inlet assembly to the pump, remove the top filter screen by releasing the four plastic blue clips. With the top filter screen off, locate the threads on the inlet of the pump inside the plastic housing.
- Go ahead and pull up on the removable plastic baffle on the plastic housing (in direct line with the inlet on pump) and remove. Now slide the auxiliary inlet in place of the removable baffle, into the plastic housing and thread the locking nut with appropriately sized O-ring onto the inlet of pump.
- Once installed, the auxiliary inlet can be adjusted to vary the flow between the auxiliary suction point and the pump enclosure. By turning the fitting on the outside of pump threads directionally "+ / -".

+ INCREASES SUCTION THROUGH PUMP SCREEN/ENCLOSURE.

- INCREASES SUCTION FROM AUXILIARY POINT IN POND OF WATER FEATURE.

FILTRATION & WATERFALL PUMPS

- Now connect a piece of tubing to the pivoting stepped adapter on auxiliary inlet of the pump and fasten firmly with hose clamps (not included).
- Direct the remaining end of tubing to either an optional accessory such as a skimmer or secondary suction point, or waterfall within pond or water feature.
- Place the pump in desired location in the pond or water feature. Ensure the pump is on a stable surface. Do not place the pump upside down.
- Ensure pump is fully submerged and double check that all plumbing connections are secure, then plug in pump power cord to test operation of pump.

CLEANING

Begin by ensuring that the main power supply is disconnected before attempting any maintenance or adjustment on the pump. Remove the unit from the water. If your unit is connected to a filter, the filters and sponges will clog up over time. Please clean regularly (at least once a week) to ensure strong water flow. Failure to maintain the unit could result in a burnt out motor and possibly other damage.

All PondMAX Filtration & Waterfall Pumps are water cooled, if pump becomes restricted, or blocked, it will overheat and could cause permanent damage. When the flow starts to be reduced, check and clean if necessary. The motor unit of the pump is encapsulated with epoxy resin and does not need lubrication. Regular inspections, cleaning and maintenance of impeller is necessary to ensure longer life. In the center of the impeller you may notice a small hole opening that protrudes through the ceramic shaft from front to back.

It is paramount that this portal is kept unblocked at all times. This is a cooling channel for the motor. Start by disconnecting the tubing from the pump. Then unclip top section of the top filter screen from off the bottom pump housing by releasing the four plastic blue clips, and then lift it off.

1. **Clean the housing and pump with a suitable brush, taking care to clean off sludge, algae and debris.**
2. **To maintain the impeller of the pump, turn the Impeller Cover in an anti-clockwise direction, to the stop position. Then separate the impeller cover from the pump motor body.**
3. **Lift out the impeller assembly. (Take care not to break ceramic shaft.) The black disc behind the blades is part of the entire Impeller assembly. Clean the impeller with clean water and a suitable brush taking note to remove fine sediment on and around the back end of the Impeller including the small hole through the ceramic shaft if it has one. Replace the Impeller if damage is visible.**
4. **Ensure that the Impeller Cover O-Ring is reinstalled in the correct place when reassembling the unit.**

IMPORTANT NOTES

It is important to ensure that maintenance is carried out regularly as the cooling path inside the motor can become clogged. If the impeller assembly becomes worn or damaged it should be replaced (available from your local dealer). Failure to do so may cause serious damage to pump. Inspect for signs for wear and tear. The impeller is a wearing consumable part. Once the cleaning and inspection process is completed, reassemble in the reverse manner. Reinstall the impeller into the motor body.

To place the Impeller Cover O-Ring around the black disc successfully, firmly hold the disc with one hand, and using the other hand stretch the Impeller Cover O-Ring over the impeller disc, positioning it carefully into the groove. Pay attention not to allow the Impeller Cover O-Ring to roll forward, in-between the black disc and the motor body. With the impeller in the correct position, carefully place the impeller cover back on, and then rotate clockwise back into position.

EXPLODED VIEW



IMPORTANT

These accessories and attachments are recommended for use with your PondMAX product specified in this manual. The use of any other accessories or attachments might present a risk of injury to persons. Only use the accessory or attachment for its stated purpose.

NOTE: IMAGE BELOW FOR ILLUSTRATION PURPOSES ONLY.

Exploded view image below reflects the model EP2300 - EP3500 specifically. Due to minor variations in design and manufacturing methods the below diagram may slightly differ for models EP700 - EP1700.

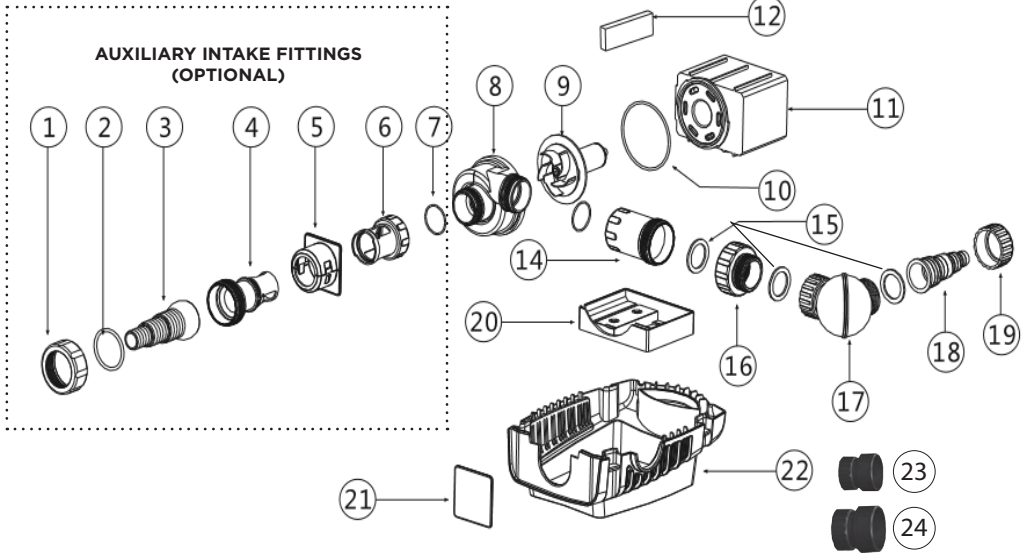

- 1. Nut
- 2. Large O-Ring
- 3. Pivoting Stepped Inlet Adapter
- 4. Auxiliary Intake Adjustment Fitting (1)
- 5. Auxiliary Flange
- 6. Auxiliary Intake Adjustment Fitting (2)

NOT PICTURED - Reducer Bushing
(Comes with EP700 - EP1700 only)

- 7. Small O-Ring
- 8. Impeller Cover
- 9. Impeller
- 10. Impeller Cover O-Ring
- 11. Pump Motor Body
- 12. Rubber Cushion
- 13. Top Filter Screen
- 14. Thread Adapter (Appears slightly different on EP700 - EP1700)
- 15. Flat Gaskets
- 16. Connection Nut
- 17. Ball Joint & Nut
- 18. Stepped Outlet Adapter
- 19. Outlet Nut
- 20. Motor Bracket
- 21. Removable Baffle
- 22. Pump Housing
- 23. SCH. 40 Adapters w/ Locking Nut - 1 1/2" Slip
(Optional - Comes with EP700 - EP2900 only)
- 24. SCH. 40 Adapters w/ Locking Nut - 2" Slip
(Optional - Comes with EP3500 only)

FILTRATION & WATERFALL PUMPS

TROUBLESHOOTING

Problem	Reason	Solution
Pump Not Working	No Power	Check that the plug is connected and turned on
	Impeller is blocked with sludge or debris	Clean the Impeller as per the instructions
	Running without sufficient water	Submerge the equipment underwater then plug in. Refill if necessary.
	Blocked Impeller chamber or ceramic shaft is broken	Clean the Impeller. Check for ware. Replace if necessary.
Pump is noisy	Blockage in pump	Clear the blockage
	Impeller & Shaft worn out	Replace Impeller & Shaft
	Impeller broken	Replace Impeller
	Debris is blocked on the outlet	Open outlet and allow water to flow
	Pump inlet is blocked	Clear all blockages

SPARE PARTS (NOTE: THESE ARE THE MOST USED)

DESCRIPTION	EP700	EP1100	EP1700	EP2300	EP2900	EP3500
IMPELLER	31PD110	31PD111	31PD112	31PD113	31PD114	31PD115
FITTING SET	31PD400			31PD410		



LIMITED PRODUCT WARRANTY

- CMT Group LLC, a California limited liability company d/b/a PondMAX™ USA (the "Company") expressly warrants to the original purchaser that, for a period of two (2) years from the date of sale, the covered product (the "Product") will be reasonably free of defects in materials and workmanship and that when properly handled, will conform, within accepted tolerance to applicable manufacturing specifications. This Limited Product Warranty ("Limited Warranty") only applies to Company's Products that are used, stored, handled, and installed in the manner recommended by the Company in the Product instruction manual.
- Notwithstanding this Limited Warranty, customer acknowledges that some parts of the Product are consumable and may need to be replaced as part of ongoing Product maintenance, as recommended in the Product instruction manual, and are therefore not covered by this Limited Warranty.
- Company will, at its option, repair or replace Product without charge, if the Product fails or does not perform as warranted solely due to a manufacturing defect within the warranty period, subject to the exclusions set forth in this Limited Warranty.
- Repair or replacement during this two (2) year warranty shall not include: reasonable labor charges necessary to repair or replace the defective Product, shipping costs, and packing and insurance costs. During the entire two (2) year warranty, Company's obligation as to repair or replacement shall further be limited to repair or replacement with the models of the Product that are available at the time of the repair or replacement, and shall be limited to the repair or replacement of only the specific Product that fails due to a manufacturing defect. Any repaired or replaced Product shall also remain subject to the original two (2) year warranty from the date of the original sale, and any repair or replacement shall not extend the original warranty period in any manner or start a new warranty period.
- You may obtain coverage under this Limited Warranty by providing Company with proof of original purchase. For service under this Limited Warranty, you must first contact the seller, distributor, retailer, or dealer from whom you purchased the Product and provide the following: copy of original receipt, your name and address, a description of the Product (including the serial number/date code set forth on the Product), and the nature of the defect. To expedite any warranty claims and processing, please submit to us the product registration card included with your purchased Product promptly after your purchase.
- All warranty repairs must be performed by the Company, or a Company authorized third-party. Any repairs performed by you or an unauthorized third-party will not be compensated by Company and are not the responsibility of the Company and will void this warranty.
- **DISCLAIMER OF WARRANTIES:** Company's Products must be stored, handled, installed, used, and maintained in accordance with instructions provided by Company, and this Limited Warranty is conditioned upon compliance with all such instructions. Copies of the Company's use guide/care guide are included with the Product and available from the Company at the address listed below. You may also obtain these materials by contacting Company at (888) 868-1185 or on the Company's website www.pondmax.com.
- This Limited Warranty does not cover defects caused by:
 - non-compliance with Company's use guides, care guides, and/or instruction manual. Such failures include, but are not limited to, exposure to physical abuse, including, but not limited to chemical abuse (e.g. harsh cleansers and solvents), thermal abuse or shock (e.g. excessive heat or cold), incompatibility of fluid used near the Product, or misuse;
 - improper storage, installation, handling, and/or use of the Product;
 - damage not resulting from manufacturing defects that occur while the Product is in the customer's possession;
 - unreasonable or unintended use of Product;
 - products installed with known or visible manufacturing defects at the time of installation;
 - minor conditions such as stains, scratches, etc.
- Any information or suggestion by Company with respect to the Products concerning applications, specifications, or compliance with codes and standards is provided solely for your convenient reference and are made without any representation as to accuracy or suitability. You must verify and test the suitability of any information with respect to the Products for your specific application.
- **THE WARRANTIES SET FORTH IN THIS LIMITED WARRANTY ARE THE ONLY WARRANTIES MADE BY COMPANY IN CONNECTION WITH THE PRODUCT. COMPANY CAN NOT AND DOES NOT MAKE ANY IMPLIED OR EXPRESS WARRANTIES WITH RESPECT TO THE PRODUCT, AND DISCLAIMS ALL OTHER WARRANTIES, INCLUDING, BUT NOT LIMITED TO, ANY WARRANTY OF MERCHANTABILITY OR FITNESS FOR A PARTICULAR PURPOSE. PRODUCTS SOLD BY COMPANY ARE SOLD ONLY TO THE SPECIFICATIONS SPECIFICALLY SET FORTH BY COMPANY IN WRITING. OTHER THAN THE LIMITED WARRANTY SET FORTH HEREIN, COMPANY MAKES NO OTHER WARRANTIES, EXPRESS OR IMPLIED. COMPANY'S SOLE OBLIGATION UNDER THIS WARRANTY SHALL BE REPAIR OR REPLACEMENT OF NON-CONFORMING PRODUCTS. BUYER ASSUMES ALL RISK WHATSOEVER AS TO THE RESULT OF THE USE OF THE PRODUCTS PURCHASED, WHETHER USED SINGULARLY OR IN COMBINATION WITH ANY OTHER PRODUCTS OR SUBSTANCES.**
- **LIMITATION OF LIABILITY:** No claim by the buyer/owner of any kind, including claims for indemnification, shall be greater in amount than the purchase price of the Product in respect to which damages are claimed. **IN NO EVENT SHALL COMPANY BE LIABLE TO BUYER/OWNER IN TORT, CONTRACT OR OTHERWISE, FOR ANY SPECIAL, INDIRECT, INCIDENTAL, CONSEQUENTIAL, RELIANCE, STATUTORY, SPECIAL, PUNITIVE OR EXEMPLARY DAMAGES, INCLUDING, BUT NOT LIMITED TO, LOST PROFITS, LOSS OF USE, LOSS OF TIME, LOSS OF REVENUES, INCONVENIENCE, LOSS BUSINESS OPPORTUNITIES, DAMAGE TO GOOD WILL OR REPUTATION, OR LOSS OF DATA, EVEN IF ADVISED OF THE POSSIBILITY OF SUCH DAMAGES OR SUCH DAMAGES COULD HAVE BEEN REASONABLY FORESEEN, IN CONNECTION WITH, ARISING OUT OF, OR AS A RESULT OF, THE SALE, DELIVERY, SERVICING, USE OR LOSS OF USE OF THE PRODUCT SOLD HEREUNDER, OR FOR ANY LIABILITY OF BUYER TO ANY THIRD PARTY WITH RESPECT THERETO.**
- All provisions of this Limited Warranty are severable and if any provision shall be deemed invalid, the remaining provisions shall remain in full force and effect.
- Please consult your retailer for quality original Company replacement parts.
- Visit www.pondmax.com for your nearest dealer.
- **Contact Information:**
 - Any question concerning this warranty should be addressed to:
PondMAX USA
P.O. Box, 341
San Leandro, CA 94577
Phone: 888.868.1185
Email: info@pondmax.com
Website address: <https://pondmax.com>